

Approved	Checked	Designed	DEVELOPMENT SPECIFICATION	TEMPORARY
		T. Takata		

T Y P E	Soft Orange Light Emitting Diode					
APPLICATION	Indicators					
MATERIAL	InGaAlP					
OUTLINE	Attached					
ABSOLUTE MAXIMUM RATINGS	P	*1 I <sub>FP</sub>	I <sub>FDC</sub>	V <sub>R</sub>	Topr	Tstg
	55	60	20	4	-30~+85	-40~+100
	mW	mA	mA	V	°C	°C
CONDITION	Ta=25±3°C					

Test Specification

I t e m	Symbol	C o n d i t i o n	Typ	Limit		Unit
				Min	Max	
Forward Voltage	V <sub>F</sub>	I <sub>F</sub> =10mA	1.95		2.5	V
Reverse Leakage Current	I <sub>R</sub>	V <sub>R</sub> = 4V			100	μA
Luminous Intensity *2	I <sub>O</sub>	I <sub>F</sub> =10mA DC	52.5	28.0		mcd
Peak Emission Wavelength	λ <sub>p</sub>	I <sub>F</sub> =10mA DC	615			nm
Spectral Line Half Width	Δλ	I <sub>F</sub> =10mA DC	20			nm

- \*1. The Condition of I<sub>FP</sub> is duty 10%, Pulse width 1 ms
- \*2. Tolerance of luminous intensity: ±20%.

NOTE

- ★1. Please contact the Panasonic local office if you design at low current (below 1mA DC) or pulse current operation and have any questions.
- ★2. Soldering conditions...Refer to Handling note.
- ★3. Compositions of the lead ... Cu/Ni/Au plating
- ★4. Beware of destruction by static electricity in handling the LED.
- ★5. Circuit to operate LED.

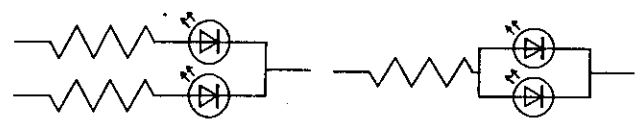

(A) Recommended circuit.  
 (B) The difference of brightness between the LED could be found due to the V<sub>F</sub> characteristics of each LED.

Nov. 7. 2001			

Approved	Checked	Designed
		T. Tabata

DEVELOPMENT SPECIFICATION

P/N: LNJ818C87RA1

TEMPORARY

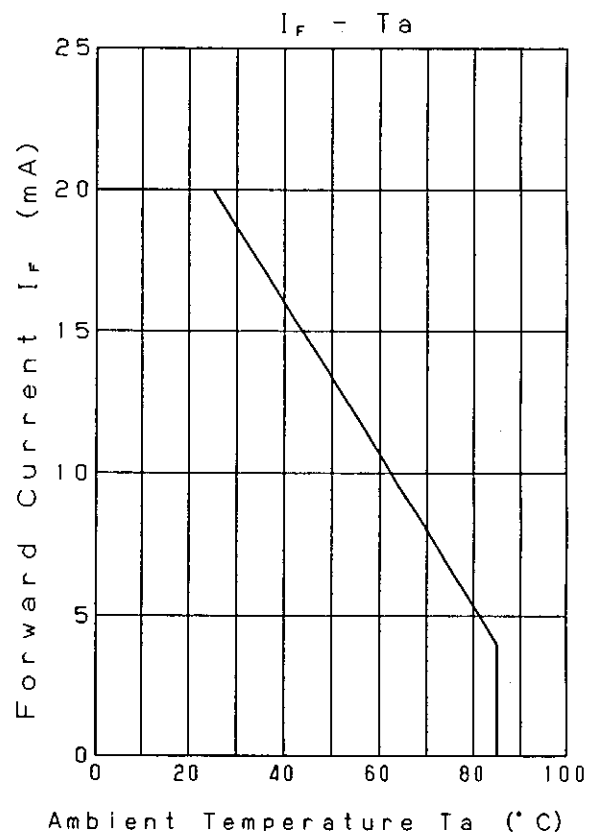
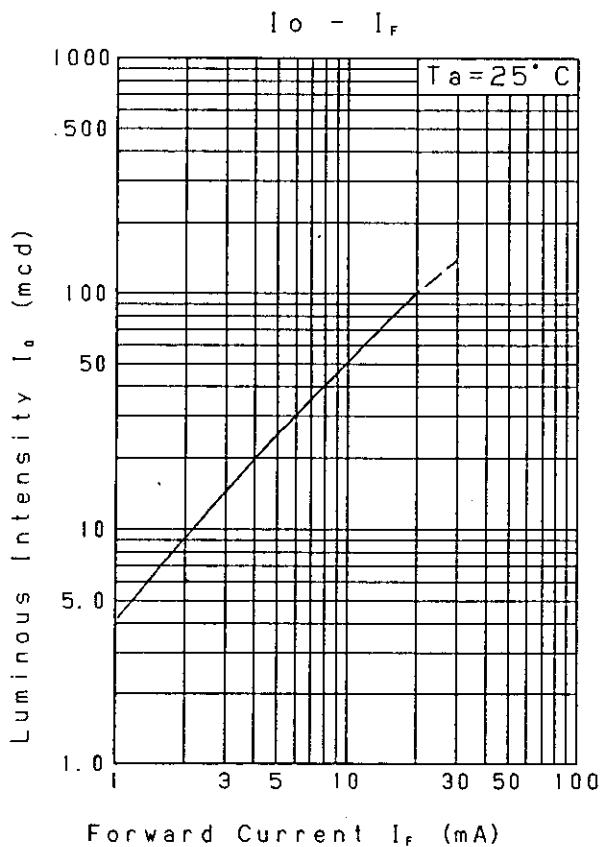
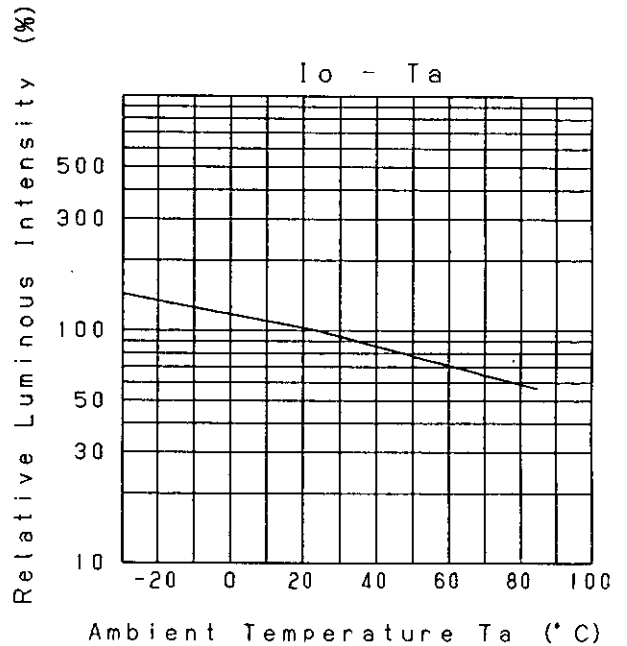
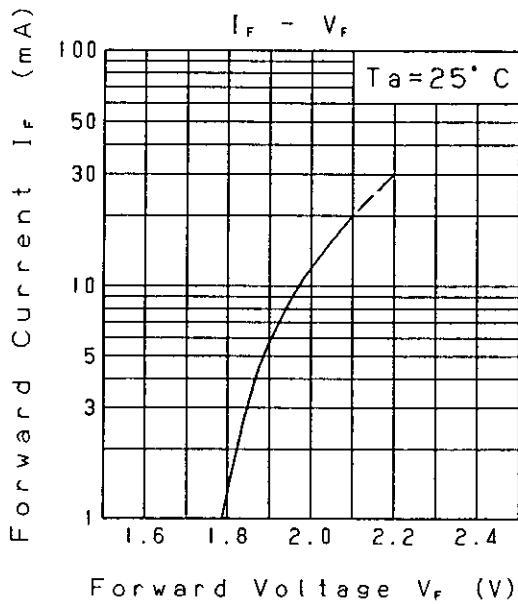

Nov. 7. 2001

Approved	Checked	Designed
		T. Takata

DEVELOPMENT SPECIFICATION

P/N: LNJ818C87RA1

TEMPORARY

Relative Luminous Intensity  
Wavelength Characteristics

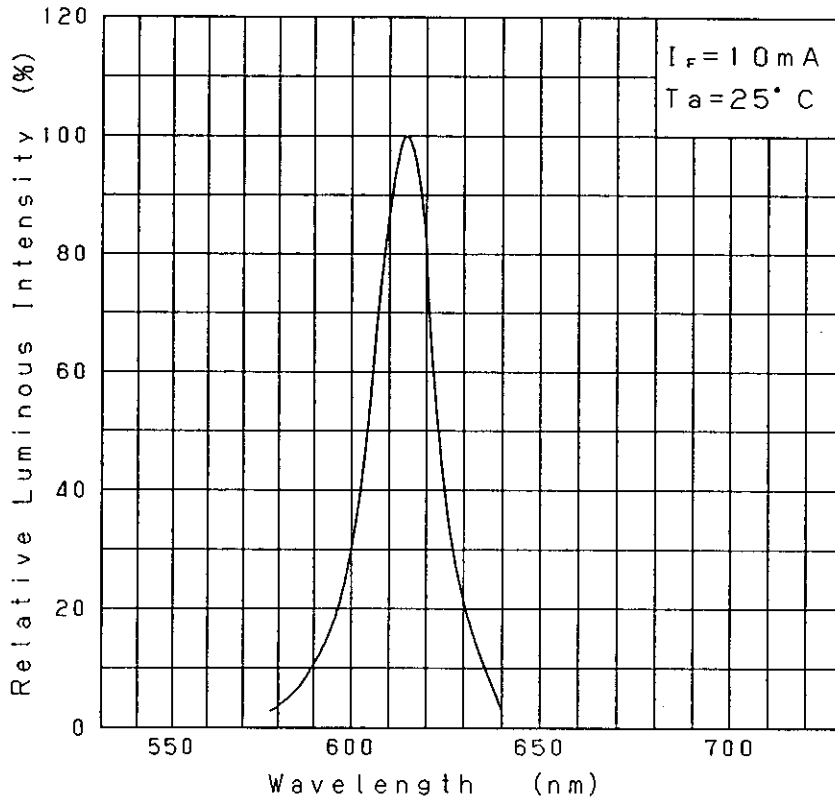

Directive Characteristics

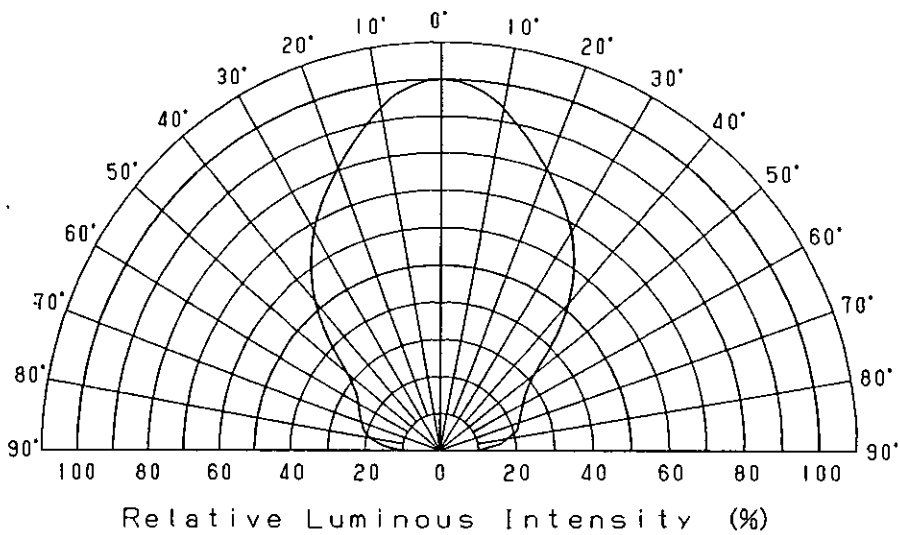

Nov. 7. 2001

Approved	Checked	Designed	DEVELOPMENT SPECIFICATION (OUTLINE)	TEMPORARY
		T. Tabata		

Outline

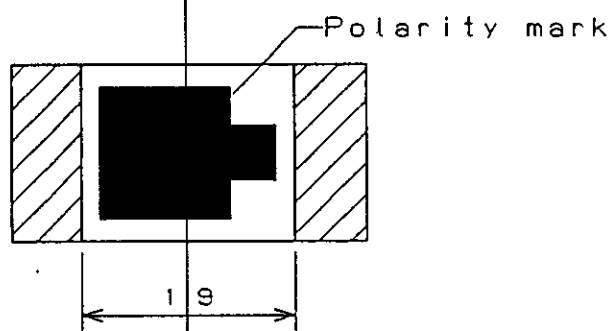
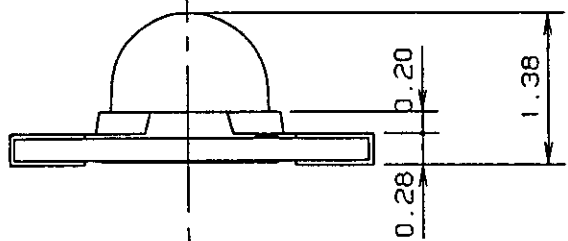
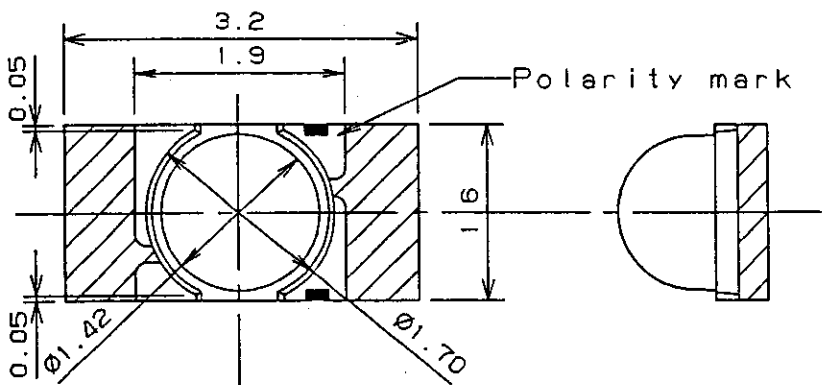

Recommended Land Layout

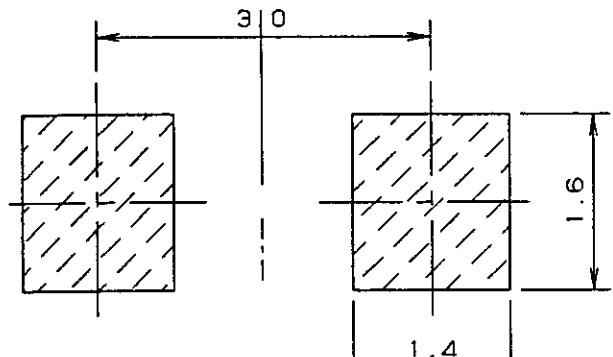

Polarity

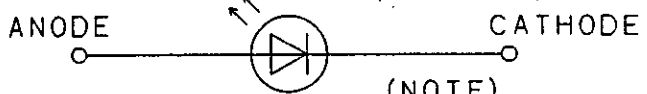

- (NOTE)
1. Unit: mm
  2. Tolerance unless specified is  $\pm 0.15$ .
  3. indicate Au terminal.

Nov. 7. 2001			
--------------	--	--	--